

IB4140-72/IB4140-72L Double Coated Tape

Version: 2
Date: 1/2021
Approved by: JNP

Product Description

IB4140-72 consists of a .5mil PET carrier coated on both sides with 1.2 mils of acrylic pressure sensitive adhesive. The adhesive is protected by a two-side silicone coated 72# polycoated Kraft liner; the “L” version has a 1.2 mil PET process liner if dual liner handling is preferred. This product is designed for applications that require a combination of high initial tack and cohesive strength.

Product Construction

- **Carrier:** 0.5 mil PET
- **Adhesive:** 1.2 mils HSA440 Acrylic
- **Liner(s):** 72# Bleached PCK; 1.2 mil PET
- **Web Width:** 54”

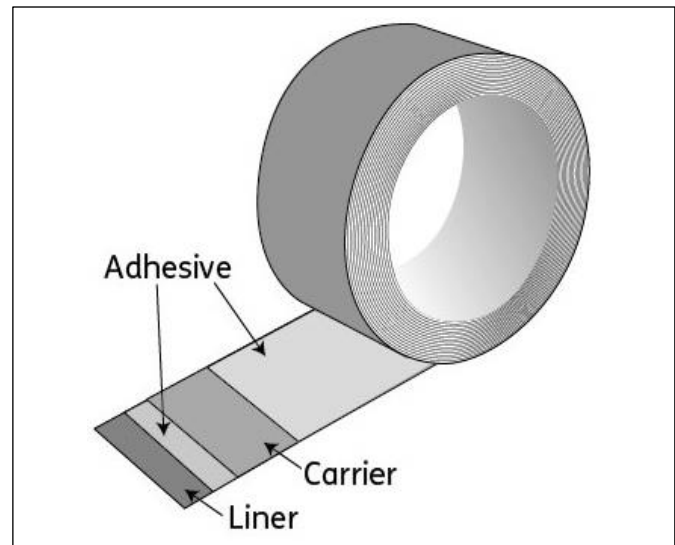

Features

- High performance acrylic adhesive
- Excellent shear properties
- Dimensionally stable poly-coated release liner.
- Dual liner version is available if 2 liners is preferred.

Benefits

- Excellent adhesion to a wide variety of substrates
- Maintains performance after heat & humidity exposure
- Solvent & UV resistant
- Non-whitening & low odor
- Excellent handling and die-cutting.
- pH Neutral adhesive

Applications

- General purpose mounting & bonding applications
- Electronics applications
- Nameplates & Overlays
- Appliance Assembly
- Medical device assembly
- Sign & Display

IB4140-72 & IB4140-72L Physical Properties			
Thickness (Mils)	IB4140-72	IB4140-72L	
Adhesive	1.2/1.2	1.2/1.2	
Carrier	0.5	0.5	
Liner (s)	5.3	5.3/1.2	
Total Thickness	8.2	9.4	
Performance Test	Test Method	Typical Values	
Loop tack	PSTC-16	Lbs./in.	Oz/in.
Stainless Steel	2 mil PET Backed	5.0	80
Peel Adhesion Duration/Substrate	PSTC-101-Method A	Lbs./in.	Oz/in.
30-min Stainless Steel	2 mil PET Backed	5.0	80
24-hr Stainless Steel		5.5	88
24-hr Polycarbonate		5.5	88
24-hr HDPE		1.5	24
Shear	PSTC-107	Hours to Fail	
1 kg weight	72°F	100+	
pH Testing	ISO18902	Neutral	
Photoactivity Testing (PAT)	ISO18916	Pass	

Values given are typical and not for use in specifications

SERVICE TEMPERATURE

Application: Above 50°F (10°C) for best performance
 End Use: -40°F to 325°F (-40°C to 163°C)

APPLICATION DETAILS

For best performance surfaces must be clean, dry and free of any oil, grease or other contaminant.

SHELF LIFE

Two-year shelf life when stored at 75°F. (24°C.) and 50% relative humidity or less. It is recommended that the product be stored in its original package until ready to use.

CALL **1-800-328-2619** for additional product information

IMPORTANT NOTICE: The information given and recommendations made herein are based on our research and are believed to be accurate. In every case, user shall determine before using any product in full scale production, whether such product is suitable for their particular purpose under their own operating conditions. User assumes all risk and liability whatsoever in connection with their use of any product. The products discussed herein are sold without any warranty as to merchantability or any other warranty, expressed or implied. No representative of ours has any authority to waive or change the foregoing provisions unless in a specific agreement signed by the officers of seller and manufacturer. Ultimately, sellers and manufacturers only obligation shall be to replace or credit such quantity of the product proved to be defective at its discretion.

™ Trademark of Morgan Adhesives Company LLC
 ® Registered Trademark of Morgan Adhesives Company LLC
 www.Mactac.com

