

IB1122-12PT Double Coated Tape

Version: 3
Date: 7/2020
Approved by: JNP

Product Description

IB1122-12PT consists of a .5mil PET carrier coated on both sides with 2.0 mils of rubber pressure sensitive adhesive. The adhesive is protected by a two-side silicone coated 12-point natural poly-coated Kraft liner. This product is designed for applications that require high initial tack to a wide variety of substrates including open cell foams and low surface energy materials.

Product Construction

- **Carrier:** 0.5 mil PET
- **Adhesive:** 2.0 mils FBR899
- **Liner:** 12 PT Board
- **Web Width:** 54"

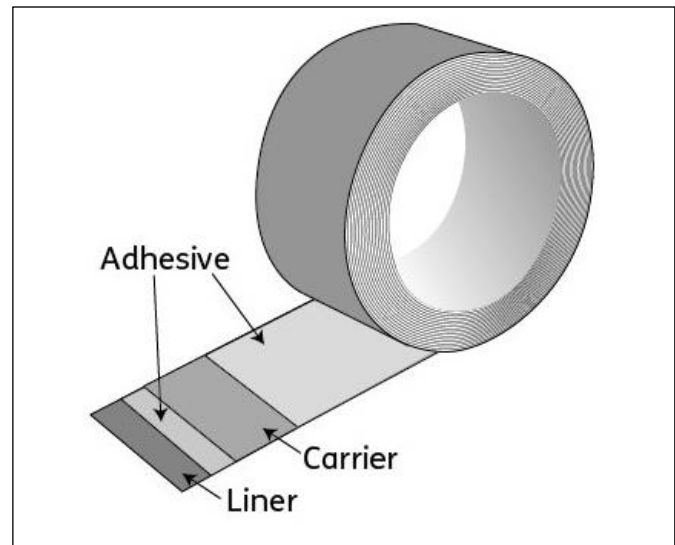

Features

- Aggressive rubber adhesive
- Good shear properties
- 12pt board liner

Benefits

- High initial tack and adhesion
- Excellent adhesion to a wide variety of substrates
- Performs well on rough or uneven surfaces
- Excellent handling and die-cutting.
- Exceptional performance on most foam and rubber materials.

Applications

- Foam bonding applications
- Felt and fabric bonding applications
- Carpet securement
- General purpose mounting & bonding applications
- Low surface energy applications.

IB1122-12pt Physical Properties			
Thickness	Mils Liner/Unwind		
Adhesive	2.0/2.0		
Carrier	0.5		
Liner	12.0		
Total Thickness	16.5		
Performance Test	Test Method	Typical Values	
Loop Tack	PSTC-16	Lbs./in.	Oz/in.
Stainless Steel	2 mil PET Backed	15	240
Peel Adhesion 2 mil PET Backed	PSTC-101-Method A	Lbs./in.	Oz/in.
Stainless Steel	2 mil PET Backed	9.5	152
Shear	PSTC-107	Hours to Fail	
1 kg weight	72°F	+200	

Values given are typical and not for use in specifications

SERVICE TEMPERATURE

Application: Above 50°F (10°C) for best performance
 End Use: -40°F to 160°F (-40°C to 71°C)

APPLICATION DETAILS

For best performance surfaces must be clean, dry and free of any oil, grease or other contaminant.

SHELF LIFE

Two-year shelf life when stored at 75°F. (24°C.) and 50% relative humidity or less. It is recommended that the product be stored in its original package until ready to use.

CALL **1-800-255-9733** for additional product information

IMPORTANT NOTICE: The information given and recommendations made herein are based on our research and are believed to be accurate. In every case, user shall determine before using any product in full scale production, whether such product is suitable for their particular purpose under their own operating conditions. User assumes all risk and liability whatsoever in connection with their use of any product. The products discussed herein are sold without any warranty as to merchantability or any other warranty, expressed or implied. No representative of ours has any authority to waive or change the foregoing provisions unless in a specific agreement signed by the officers of seller and manufacturer. Ultimately, sellers and manufacturers only obligation shall be to replace or credit such quantity of the product proved to be defective at its discretion.

™ Trademark of Morgan Adhesives Company LLC
 ® Registered Trademark of Morgan Adhesives Company LLC
 www.Mactac.com

