

IF4375-72

LSE427 Acrylic Tissue Based Tape

Version: 1
Date: 5/2018
Approved by: JNP

Product Description

IF4375-72 is a 5-mil thick tissue reinforced high-performance acrylic pressure sensitive adhesive. The adhesive is protected by a two-side silicone coated 72# polycoated Kraft liner. This product is designed for applications that require adhesion to low surface energy and other challenging substrates.

Product Construction

- **Carrier:** Tissue
- **Adhesive:** LSE427 Acrylic
- **Liner:** 72# Bleached PCK
- **Web Width:** 54"

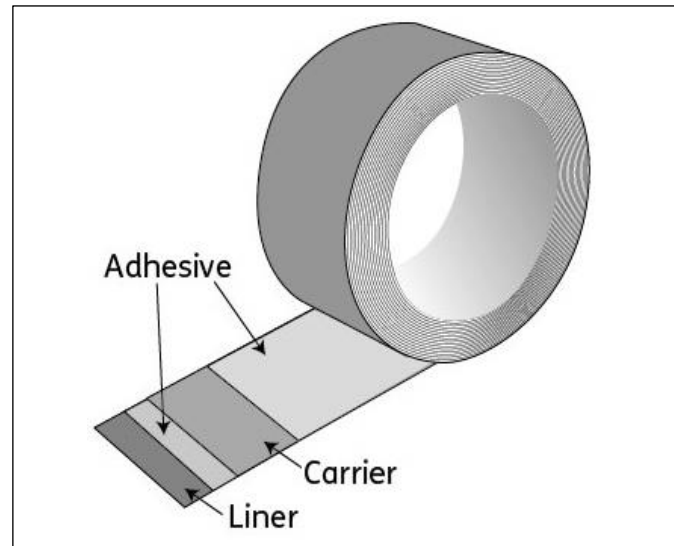

Features

- High performance acrylic adhesive
- Good shear properties
- Moisture stable PCK liner
- Double Liner available

Benefits

- High initial tack and adhesion to most substrates
- Excellent for uneven or rough surfaces
- Water & Humidity resistant
- Chemical resistant
- Conformable
- Excellent die cutting properties

Applications

- General purpose mounting & bonding applications
- Foam bonding applications
- Decorative Trim
- Nameplate or Faceplate Mounting
- Graphic Mounting Applications
- Mounting to powder coated metals

IF4375-72 Physical Properties			
Thickness	Mils	MM	Microns
Adhesive & Tissue	5.0	.1270	127
Liner	5.8	.1473	147.3
Total Thickness	10.8	.2743	274.3
Performance Test	Test Method	Typical Values	
Loop tack	PSTC-16-Method A	Lbs./in.	Oz/in.
Stainless Steel	Backed with 2 mil PET	8.6	137.6
HDPE		4.5	72
Peel Adhesion 2 mil PET Backed	PSTC-101-Method A	Lbs./in.	Oz/in.
30 minute dwell	Stainless Steel	8.5	136
24 hour dwell	Stainless Steel	8.8	140.8
30 minute dwell	HDPE	3.6	57.6
24 hour dwell	HDPE	4.0	64
30 minute dwell	TPO	4.6	73.6
24 hour dwell	TPO	4.7	75.2
30 minute dwell	PP	5.2	83.2
24 hour dwell	PP	7.0	112
30 minute dwell	LDPE	3.7	59.2
24 hour dwell	LDPE	6.5	104
Shear	PSTC-107-Method A	Hours to Fail	
1 kg weight	72°F	55+	

Values given are typical and not for use in specifications

SERVICE TEMPERATURE

Application: Above 50°F (10°C) for best performance
 End Use: -40°F to 350°F (-40°C to 177°C)

APPLICATION DETAILS

For best performance surfaces must be clean, dry and free of any oil, grease or other contaminant.

SHELF LIFE

Two year shelf life when stored at 75°F. (24°C.) and 50% relative humidity or less. It is recommended that the product be stored in its original package until ready to use.

CALL **1-800-328-2619** for additional product information

IMPORTANT NOTICE: The information given and recommendations made herein are based on our research and are believed to be accurate. In every case, user shall determine before using any product in full scale production, whether such product is suitable for their particular purpose under their own operating conditions. User assumes all risk and liability whatsoever in connection with their use of any product. The products discussed herein are sold without any warranty as to merchantability or any other warranty, expressed or implied. No representative of ours has any authority to waive or change the foregoing provisions unless in a specific agreement signed by the officers of seller and manufacturer. Ultimately, sellers and manufacturers only obligation shall be to replace or credit such quantity of the product proved to be defective at its discretion.

™ Trademark of Morgan Adhesives Company LLC
 ® Registered Trademark of Morgan Adhesives Company LLC
 www.Mactac.com

