

IB1122-60/IB1122-60ER Double Coated Tape

Version: 3
Date: 6/2020
Approved by: JNP

Product Description

IB1122-60 consists of a .5mil PET carrier coated on both sides with 2.0 mils of rubber pressure sensitive adhesive. The adhesive is protected by a two-side silicone coated 60# white super-calendared Kraft liner, available with either medium-easy release (ER) or medium-tight release. This product is designed for applications that require high initial tack to a wide variety of substrates including open cell foams and low surface energy materials.

Product Construction

- **Carrier:** 0.5 mil PET
- **Adhesive:** 2.0 mils FBR899
- **Liner:** 60# White SCK
- **Web Width:** 60"

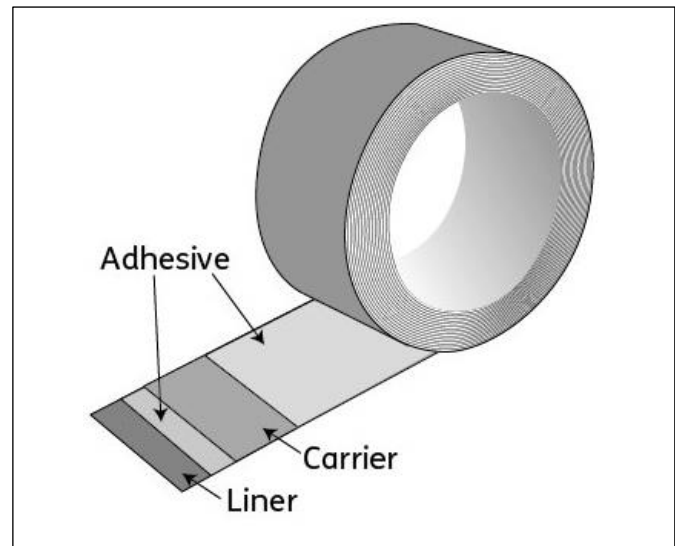

Features

- Aggressive rubber adhesive
- Good shear properties
- Dimensionally stable SCK liner.

Benefits

- High initial tack and adhesion
- Excellent adhesion to a wide variety of substrates
- Performs well on rough or uneven surfaces
- Excellent handling and die-cutting.
- Exceptional performance on most foam and rubber materials.

Applications

- Foam bonding applications
- Felt and fabric bonding applications
- Carpet securement
- General purpose mounting & bonding applications

IB1122-60 Physical Properties			
Thickness	Mils Liner/Unwind		
Adhesive	2.0/2.0		
Carrier	0.5		
Liner	3.5		
Total Thickness	8.0		
Performance Test	Test Method	Typical Values	
Loop Tack	PSTC-16	Lbs./in.	Oz/in.
Stainless Steel	2 mil PET Backed	12.0	192
Peel Adhesion	PSTC-101-Method A	Lbs./in.	Oz/in.
Stainless Steel	2 mil PET Backed	9.5	152
Shear	PSTC-107	Hours to Fail	
1 kg weight	72°F	200+	

Values given are typical and not for use in specifications

SERVICE TEMPERATURE

Application: Above 50°F (10°C) for best performance
 End Use: -40°F to 160°F (-40°C to 71°C)

APPLICATION DETAILS

For best performance surfaces must be clean, dry and free of any oil, grease or other contaminant.

SHELF LIFE

Two year shelf life when stored at 75°F. (24°C.) and 50% relative humidity or less. It is recommended that the product be stored in its original package until ready to use.

CALL **1-800-255-9733** for additional product information

IMPORTANT NOTICE: The information given and recommendations made herein are based on our research and are believed to be accurate. In every case, user shall determine before using any product in full scale production, whether such product is suitable for their particular purpose under their own operating conditions. User assumes all risk and liability whatsoever in connection with their use of any product. The products discussed herein are sold without any warranty as to merchantability or any other warranty, expressed or implied. No representative of ours has any authority to waive or change the foregoing provisions unless in a specific agreement signed by the officers of seller and manufacturer. Ultimately, sellers and manufacturers only obligation shall be to replace or credit such quantity of the product proved to be defective at its discretion.

™ Trademark of Morgan Adhesives Company LLC
 ® Registered Trademark of Morgan Adhesives Company LLC
 www.Mactac.com

