

## IM1810XTW60 Double Coated Foam Tape

Version: 1  
Date: 8/2016  
Approved by: JNP

### Product Description

IM1810XTW60 consists of a 1/16" white, closed-cell polyethylene foam carrier coated on both sides with 2.6 mils of aggressive rubber-based pressure sensitive adhesive. The adhesive is protected by a two-side silicone coated 81# brown PCK liner. This product is designed for indoor mounting applications that require high shear performance.

### Product Construction

- **Carrier:** 1/16" white PE foam
- **Adhesive:** 2.6 mils XT Rubber
- **Liner:** 81# brown PCK
- **Web Width:** 60#

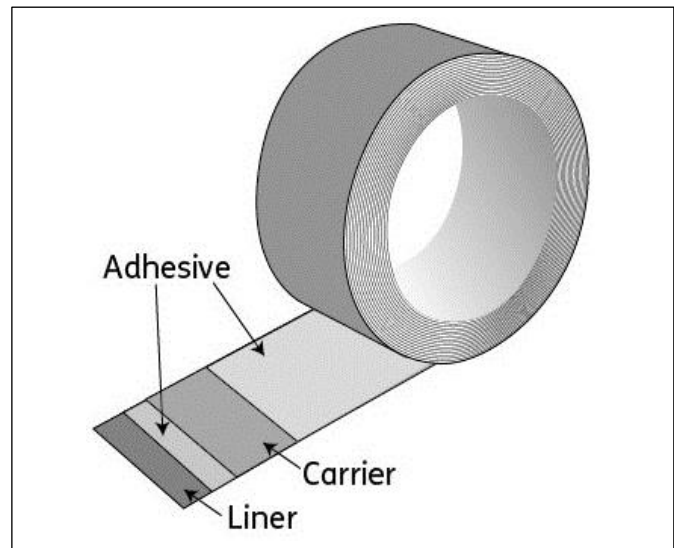

### Features

- Aggressive rubber based adhesive.
- 1/16" Foam Carrier
- 81# natural brown poly-coated release liner.

### Benefits

- Heavy coat weight XT Rubber adhesive performs well on both smooth & irregular surfaces.
- Excellent LSE performance
- Superior shear strength
- Foam carrier allows for maximum conformability
- Dimensionally stable liner is ideal for die cutting and handling.

### Applications

- General purpose mounting & bonding applications
- Insulation bonding.
- Foam Mounting
- Screw Anchors
- Mirror Mounting

IM1810XTW60 Physical Properties			
Thickness	Mils Liner/Unwind	MM Liner/Unwind	Microns Liner/Unwind
Adhesive	2.6/2.6	.0660/.0660	66.0/66.0
Carrier	62.50	1.59	1590
Liner	5.9	.0889	88.9
Total Thickness	73.60	1.81	1810.9
Performance Test	Test Method	Typical Values	
Loop tack	PSTC-16-Method A	Lbs./in. Liner/Unwind	Oz/in. Liner/Unwind
Stainless Steel	Backed with 2 mil PET	10.7/14.5	171/232
Peel Adhesion 2 mil PET Backed	PSTC-101-Method A	Lbs./in. Liner/Unwind	Oz/in. Liner/Unwind
30 minute dwell	Stainless Steel	7.0/8.5	112/136
Shear	PSTC-107-Method A	Hours to Fail	
1 kg weight	72°F	500+	
5 Lbs weight	72°F	200+	
Tensile	ASTM-D882	Lbs./in.	
MD/CD		145/105	
Elongation	ASTM-D882	%	
MD/CD		339/308	

Values given are typical and not for use in specifications

#### SERVICE TEMPERATURE

Application: Above 50°F (10°C) for best performance

End Use: -0°F to 180°F (-18°C to 82°C)

#### CHEMICAL RESISTANCE

Resistant to water, detergent and alcohol. Not recommended for use in contact with aliphatic or aromatic hydrocarbons.

#### APPLICATION DETAILS

For best performance surfaces must be clean, dry and free of any oil, grease or other contaminant.

#### SHELF LIFE

Two year shelf life when stored at 75°F. (24°C.) and 50% relative humidity or less. It is recommended that the product be stored in its original package until ready to use.

CALL **1-800-328-2619** for additional product information

**IMPORTANT NOTICE:** The information given and recommendations made herein are based on our research and are believed to be accurate. In every case, user shall determine before using any product in full scale production, whether such product is suitable for their particular purpose under their own operating conditions. User assumes all risk and liability whatsoever in connection with their use of any product. The products discussed herein are sold without any warranty as to merchantability or any other warranty, expressed or implied. No representative of ours has any authority to waive or change the foregoing provisions unless in a specific agreement signed by the officers of seller and manufacturer. Ultimately, sellers and manufacturers only obligation shall be to replace or credit such quantity of the product proved to be defective at its discretion.

™ Trademark of Morgan Adhesives Company LLC

® Registered Trademark of Morgan Adhesives Company LLC

www.Mactac.com

