

IF3051W52 Double Lined Transfer Adhesive

Version: 1
Date: 5/2016
Approved by: JNP

Product Description

IF3051W52 is a 1 mil thick general purpose acrylic transfer adhesive. The adhesive is protected by 2 release liners, a 2.5 mil paper easy release liner and a 3.2 mil liner coated with tight release and is designed to be remain intact for end-user removal.

Product Construction

- **Carrier:** NA
- **Adhesive:** 1.0 mil MP310 GP Acrylic
- **Liner:** 2.5 mil SCK (easy); 3.2 mil SCK (tight)
- **Web Width:** 52"

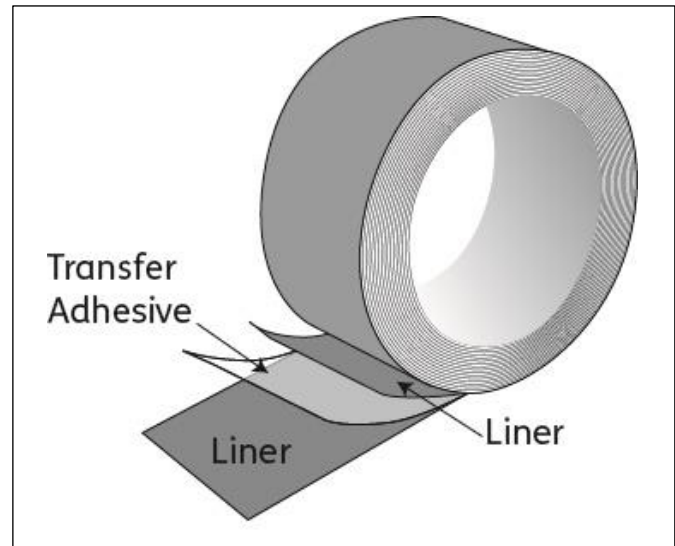

Features

- General purpose acrylic adhesive
- Good tack and shear properties
- Double liner

Benefits

- Excellent adhesion to a wide variety of substrates
- Solvent & UV resistant
- Conformable
- Double liner for ease of handling
- Good temperature resistance

Applications

- General purpose mounting & bonding applications
- Magnet laminating
- Label Converting

