

## IB1188XT Double Coated Tape

Version: 1  
Date: 8/2016  
Approved by: JNP

### Product Description

IB1188XT consists of a .5mil PET carrier coated on both sides with 2.0 mils of aggressive rubber-based pressure sensitive adhesive. The adhesive is protected by a two-sided silicone coated 80# white SCK liner. This product is designed for general purpose bonding applications on semi-smooth surfaces and has excellent performance on LSE substrates.

### Product Construction

- **Carrier:** 0.5 mil PET
- **Adhesive:** 2.0 mils MP593XT Rubber
- **Liner:** 80# White SCK
- **Web Width:** 54"

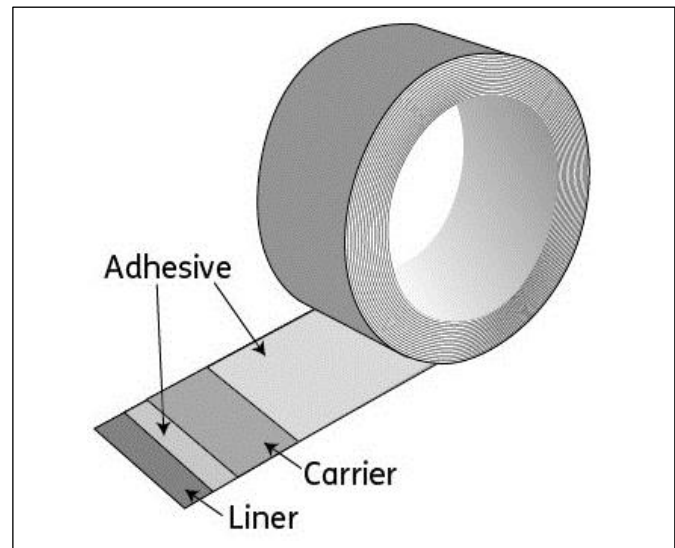

### Features

- Aggressive rubber based adhesive.
- Excellent shear properties
- 80# White SCK liner

### Benefits

- High initial tack and adhesion
- Excellent adhesion to a wide variety of substrates
- Outstanding handling and die-cutting.
- Performs well on most LSE surfaces
- 80# SCK liner is excellent for hand application of die cut parts.

### Applications

- General purpose mounting & bonding applications
- Foam Fabrication
- Felt and Fabric Bonding
- Appliance Assembly
- Building & Construction
- Automotive Interior
- Gasket Fabrication
- Insulation Installation

IB1188XT Physical Properties			
Thickness	Mils Liner/Unwind	MM Liner/Unwind	Microns Liner/Unwind
Adhesive	2.0/2.0	.0508/.0508	50.8/50.8
Carrier	0.5	.0127	12.7
Liner	4.4	.1118	111.8
Total Thickness	8.9	.2261	226.1
Performance Test	Test Method	Typical Values	
Loop tack	PSTC-16-Method A	Lbs./in. Liner/Unwind	Oz./in. Liner/Unwind
Stainless Steel	Backed with 2 mil PET	12.0/12.0	192/192
Peel Adhesion 2 mil PET Backed	PSTC-101-Method A	Lbs./in. Liner/Unwind	Oz./in. Liner/Unwind
30 minute dwell	Stainless Steel	12.0/12.0	192/192
Shear	PSTC-107-Method A	Hours to Fail	
1 kg weight	72°F	500+	
5 Lbs weight	72°F	200+	
Tensile	ASTM-D882	Lbs./in.	Oz./in.
MD/CD		10	160
Elongation	ASTM-D882	%	
MD		100	
Foam Bonding Performance			
Substrate	Application Method	Result	
EPDM	RT with 50% Compression	Aggressive Adhesion	
Nitrile PVC	RT with 50% Compression	Foam Destruction	
Neoprene	RT with 50% Compression	Foam Destruction	
EVA Blend	RT with 50% Compression	Foam Destruction	

Values given are typical and not for use in specifications

#### SERVICE TEMPERATURE

Application: Above 50°F (10°C) for best performance  
End Use: -0°F to 180°F (-18°C to 82°C)

#### CHEMICAL RESISTANCE

Resistant to water, detergent and alcohol. Not recommended for use in contact with aliphatic or aromatic hydrocarbons.

#### APPLICATION DETAILS

For best performance surfaces must be clean, dry and free of any oil, grease or other contaminant.

#### SHELF LIFE

Two year shelf life when stored at 75°F. (24°C.) and 50% relative humidity or less. It is recommended that the product be stored in its original package until ready to use.

CALL **1-800-328-2619** for additional product information

**IMPORTANT NOTICE:** The information given and recommendations made herein are based on our research and are believed to be accurate. In every case, user shall determine before using any product in full scale production, whether such product is suitable for their particular purpose under their own operating conditions. User assumes all risk and liability whatsoever in connection with their use of any product. The products discussed herein are sold without any warranty as to merchantability or any other warranty, expressed or implied. No representative of ours has any authority to waive or change the foregoing provisions unless in a specific agreement signed by the officers of seller and manufacturer. Ultimately, sellers and manufacturers only obligation shall be to replace or credit such quantity of the product proved to be defective at its discretion.

™ Trademark of Morgan Adhesives Company LLC

® Registered Trademark of Morgan Adhesives Company LLC

www.Mactac.com

